

F-1300BT

SPEAKER SYSTEM

The F-1300 Series Speaker are compact two-way speaker systems designed for high efficiency, wide range, and high power input handling capability. These speaker systems can be installed in a manner ideal for the location and intended application.



Order no: F-1300BT

Specifications

Frequency response	80 Hz - 20 kHz
Connection	Clamp terminal
Sensitivity (1#V, 1#m) (combined)	90 dB
Speaker component	Low: 13 cm cone-type, High: 2.5 cm balanced dome-type
Directivity angle horizontal	110 °
Directivity angle vertical	100 °
Rated input	30 W
Tappings	100 V (30 / 10 / 3 / 1 W), 70 V (30 / 15 / 5 / 1.5 / 0.5 W)
Rated impedance	100 V, 70 V
Crossover frequency	2 kHz
Power handling capacity	50 W (continuous pink noise), 150 W (continuous program) in 8Ω mode
Dimensions (W x H x D)	162 x 250 x 161 mm
Dimensions (ø x D)	x 161 mm
Finish	HIPS resin, black (RAL 9011 or equivalent)

F-1300BT

SPEAKER SYSTEM

Appearance

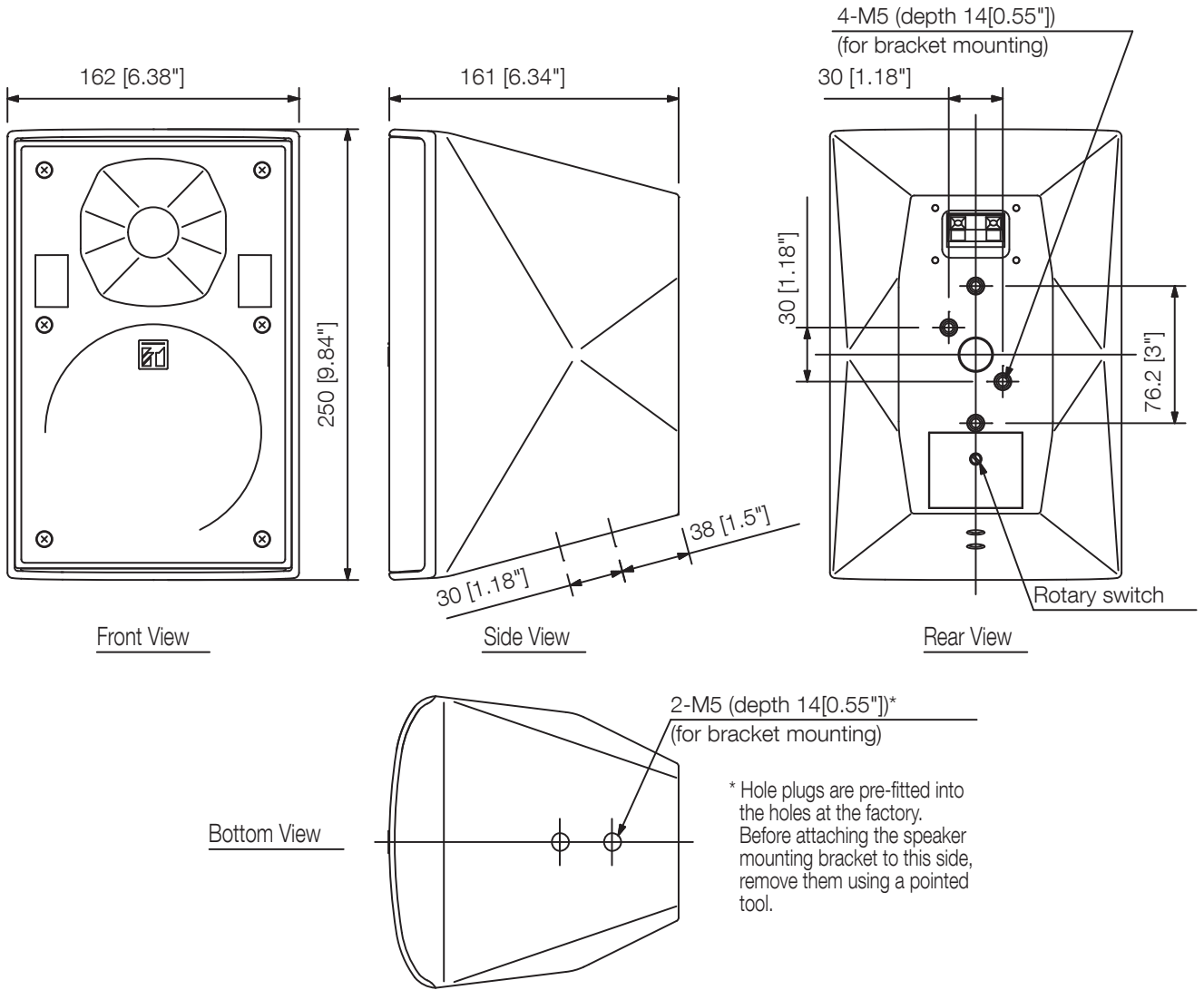

UNIT:mm SCALE:1/4